

Other HEMCO Products



UniFlow CE AirStream



UniFlow SE AirStream High Performance Energy Efficient Laboratory Fume Hoods



UniFlow LE AirStream



Safety Equipment



UniFlow LE FM



Visit www.HEMCOcorp.com

HEMCO Corporation
711 S. Powell Road
Independence MO, 64056
MM-AUXAIRE.11.25

HEMCO
Lab Planning Solutions

Phone (816) 796-2900
Fax (816) 796-3333
Email: info@HEMCOcorp.com

Installation, Operation, Maintenance Manual UniFlow Auxiliary Air Laboratory Fume Hood

Model Numbers # 21421, 21521, 21621, 21821,
21423, 21523, 21623, 21823



HEMCO Visit www.HEMCOcorp.com
Lab Planning Solutions

HEMCO Corporation
711 S. Powell Road
Independence MO, 64056

Email info@HEMCOcorp.com
Phone (816)796-2900
Fax (816)796-3333



Upon Receiving Fume Hood

- **HEMCO** fume hoods are shipped palletized, fully crated, padded, and wrapped for maximum protection and ease of handling. Upon receiving, inspect for crate damage and possible concealed damage that may have occurred in transit. Save all delivery receipts and crating materials. If damaged, promptly call **HEMCO** at (816) 796-2900. Damage must be reported immediately for a claim to be processed.

- When uncrating the fume hood remove the band strap, which is securing the corrugate to the pallet.

- When ready to install fume hood, carefully lift from pallet and set on work surface in proper location (see fume hood Installation).

CAUTION: DO NOT lift the fume hood at any time by the airfoil as this will damage the unit. Fig 1



Figure 1

SITE PREPARATION

A fume hood requires that it be installed on a level surface. If fume hood base cabinets are included with the fume hood installation make sure the floor is clean and level.

All service lines for the Fume hood installation, such as water, air, gas, etc. should be purged of dirt, capped and tested prior to connection to the fume hood.

Laboratory fume hoods should be located to avoid cross-currents at the fume hood face due to heating, cooling or ventilation inlets.

Fume hoods should be located away from high traffic lanes within the lab to avoid air that could draw hazardous fumes into the room.

Passing personnel should provide sufficient aisle space in front of the fume hood to avoid disruption of the work or interference with the operating technician.

Safety devices such as drench showers, eyewash stations, fire extinguishers, first aid kits and fire blankets should be located convenient to the fume hood operating personnel and plainly labeled as to their use and function.

In addition, laboratory fume hoods are potential locations for fires and explosions due to the type of experiments conducted in these units. As such, fume hoods should be located so an explosion or fire within the hood would not impede exit from the lab

BASE CABINET INSTALLATION

Position the cabinets in the desired location approximately 7 inches from a rear wall or in a suitable island location. Top of the cabinet should be leveled using the adjustment feet on the bottom of the cabinet. If multiple cabinets are involved, bolt them together and then bolt to existing cabinets or walls and level as one unit. Fig 2



Figure 2

WORK SURFACE

Once the fume hood base cabinet is installed apply an adhesive to the top surface of the cabinet. Fig.3

Carefully place work surface on cabinet and make any corrections the position/alignment. Allow adhesive to dry before setting fume hood. Fig.4

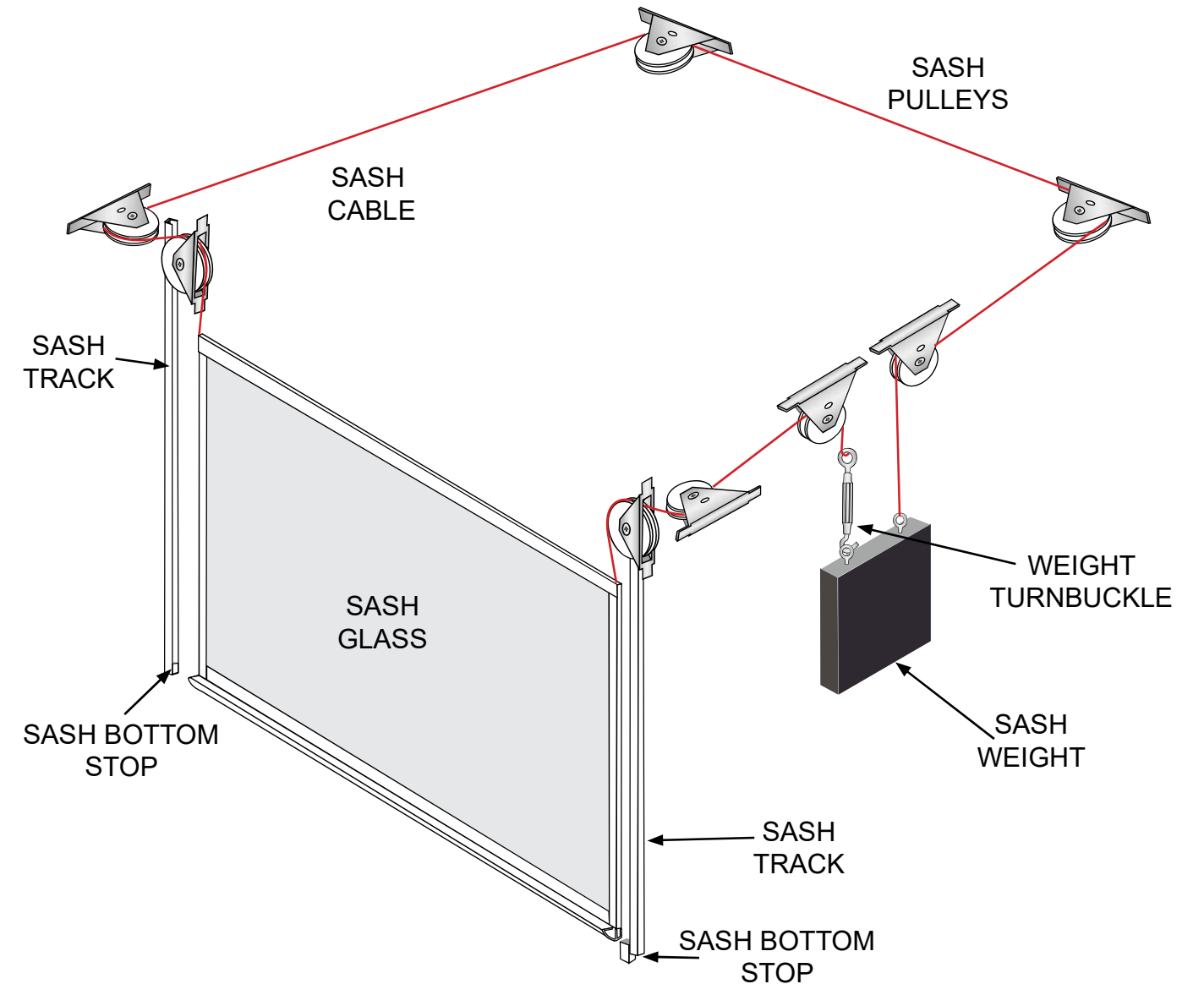

Figure 3



Figure 4

Notes:



Detail: 1 Cable connecting to sash.



Detail: 2 Sash bottom stop located in track just above airfoil.

Laboratory Safety for Chemical Fume Hoods

The Fume Hood is often the primary control device for protecting laboratory workers when working with toxic and/or flammable chemicals. OSHA's Laboratory Standard (29 CF 1910.1450) requires that fume hoods be maintained and function properly when used.

Before using the Fume Hood:

- Make sure that you understand how the Fume Hood works.
- You should be trained to use it properly.
- Know the hazards of the chemical you are working with; refer to the chemical (MSDS) Material Data Safety Sheet if you are unsure.
- Ensure that the Fume Hood is turned on.
- Make sure that the sash is open to the proper operating level, which is usually indicated by arrows on the frame.
- Make sure that the air gauge indicates that the airflow is within the required range.

When using the Fume Hood:

- Never allow your head to enter the plane of the hood opening. For example, for vertical rising sashes, keep the sash below your face; for horizontal sliding sashes, keep the sash positioned in front of you and work around the side of the sash.
- Use appropriate eye protection.
- Be sure that nothing blocks the airflow through the baffles or through the baffle exhaust slots.
- Elevate large equipment (e.g. a centrifuge) at least (2) inches off the base of the hood interior.
- Keep all materials inside the hood at least (6) inches from the sash opening. When not working in the hood, close the sash.
- Do not permanently store any chemicals inside the hood.
- Promptly report any hood that is not functioning properly to your supervisor. The sash should be closed and the hood "tagged" and taken out of service until repairs can be completed.
- When using extremely hazardous chemicals, understand your laboratory's action plan in case an emergency, such as a power failure, occurs

Fume Hood Installation

1. Fume hood must be set on a work surface or a flat level surface, Fig 5 supported by a base cabinet or table. The Fume hood is a lab furnishing and shall **NOT** be installed in the walls, ceiling or any other structural feature of the building.
2. **DO NOT** lift the fume hood at any time by the airfoil as this will damage unit.
3. Once the fume hood is in place, service lines can be connected (See Electric and Plumbing).



Figure 5

4. Service panels are provided to allow access for service hookup. Outer service panels are removed by gently prying the inner panel away from the outer trim ring at the clearance spots. Inner service panels are removed by unlocking the locking spline of the rubber sealing gasket creating tolerance to remove the gasket and inner panel. Panels may be set aside for later replacement after the installation is complete. The front access panel above the sash is removable to allow access to the top of the fume hood (pull out on lower edge of upper most panel and push up to remove). The electrical junction box, light fixture, outlet collar for duct connection, special plumbing connections, and sash weight can be accessed / installed from this position.



Figure 6

5. Fume hoods are equipped with a tempered glass sash. Sash weight(s) are packed separately in a box on the pallet.

The sash counter balance weight(s), installation can be accessed from the top of the fume hood. Fig 6.

Hook turnbuckle into right top hook of sash weight Fig 7.



Figure 7



Figure 8

- Hang sash weight(s) onto the two cable loops Fig 8.

The sash cable should ride fully in the pulley grooves prior to releasing the full weight of the counter weight. While maintaining sash cable to pulley alignment.

Once, the weight has been transferred, properly balance the sash using the adjustable mechanism (turnbuckle) located above the counter weight (right side). Fig 9.



Figure 9

6. A bead of white or clear silicone sealant should be applied between the work surface and the fume hood. Fig 10

7. Reinstall front access panel and service panels. Fig 11

8. Finally clean up with Formula Glass Cleaner.

9. To address seismic codes consult local codes that may apply to Fume Hood Installation.



Figure 10



Figure 11

Electrical & Plumbing Service/Airflow Monitors

NOTE: In those areas where seismic codes are a consideration, it is recommended that qualified engineers be consulted for necessary installation requirements for seismic codes.

ELECTRICAL SERVICES:

Electrical services supplied with your fume hood are factory mounted wired to junction box on top of the fume hood. Final wiring must be completed by a licensed electrician to comply with local codes. Supply wiring requirements:

- 20 amperes circuit use 12 gauge wire and 14 gauge ground wire size.
- 15 amperes circuit use 14 gauge wire and 14 gauge ground wire size.

It is required that the main junction box be grounded and that an external disconnect device, circuit breaker, and/or over-current device be located in the power source supply wiring, and be provided in close proximity to the fume hood. This disconnect device shall be marked as the disconnect device for the fume hood and easily accessible.

STANDARD FLUORESCENT OR INCANDESCENT LIGHT FIXTURE- is factory mounted & wired to a single point junction box

EXPLOSION PROOF FIXTURES-are installed but not wired

NOTE: Fluorescent tubes and/or bulbs are not provided with the Fume Hood. To install fluorescent tubes lift off front access panel. With a Phillips screwdriver remove the (2) screws to hinge back fixture housing and allow access to the fluorescent tubes for installation. For those fume hoods with explosion proof lights, the fixture positions in a flanged cutout. The top of the fixture threads off for wiring and the lower globe threads off for installation or replacement of incandescent bulb or spiral fluorescent tubes.

PLUMBING SERVICES:

Caution: Be sure that plumbing lines are clean and free of any residue and particulate. All plumbing service fixtures require plumbing to and from the supply source. Piping should have a solvent and corrosion resistant finish. Piping should be the best material for material being conveyed. Material types are typically copper, stainless steel, black pipe, galvanized pipe, CPVC, and PVC. A certified plumber should be used for all installation. Installation shall be installed in compliance with Local and NFPA Standards. When Plumbing connections are made, make sure lines are clear and free of debris.

Not limited to the following:

- Fuel gases such as manufactured, natural, and LP-Gas – National Fuel Gas Code, NFPA 54, and the Liquefied Petroleum Gas Code, NFPA 58.
- Hydrogen – Standard for Gaseous Hydrogen Systems at Consumer Site, NFPA 50A.
- Acetylene, oxygen systems – Standard for Design and Installation of Oxygen-Fuel Gas Systems for Welding, Cutting, and Allied Processes, NFPA 51.

AIRFLOW MONITORS: Installation and Calibration Instructions are provided with Monitor

TROUBLE SHOOTING

PROBLEM	CAUSE	CORRECTIVE ACTION
Insufficient air flow	1) Improperly sized blower 2) Motor (impeller wheel) is running backwards 3) Obstruction in duct system 4) Leaks in duct system 5) Overloaded filters	1) Resize blower, change drive package 2) Correct wiring for reverse rotation of motor. 3) Locate and Remove obstruction 4) Trace and repair 5) Clean or replace filters
Fume Hood or Blower not operating	1) Blown fuse or open circuit breaker 2) Defective motor 3) Thermal protector on 4) Motor improperly wired	1) Replace fuse or reset circuit breaker 2) Consult factory 3) Check for high or low voltage input or ambient temperatures over 40 degree C (104 degree F) 4) Correct wiring for reverse rotation of motor
Contaminates outside fume hood face	1) Improper use or procedures 2) External factors 3) Improper face velocity	1) Follow safety guidelines and procedures 2) Check external air flow patterns around fume hood 3) Recertify fume hood face velocity and/or duct system
Sash binding	4) Cable off of pulley Cable Broke	5) Replace Sash / Cable
Air Flow Monitor	6)	7)
Electrical Services not working	8) Circuit Breaker 10)Corroded Contacts	9) Check Main Load Center 11)Clean or replace

SAFETY RECOMMENDATIONS

- DO** - AVOID UNNECESSARY EXPOSURE OF PERSONNEL TO FUMES INSIDE HOOD BY KEEPING SASH CLOSED EXCEPT WHEN LOADING OR UNLOADING HOOD.
- DO** - KEEP MATERIALS 6" OR MORE FROM FRONT EDGE OF SASH PLANE.
- DO** - KEEP THE SASH AT DESIGN OPENING WHILE UTILIZING THE FUME HOOD.
- DO** - CLEAN UP IMMEDIATELY ANY MAJOR SPILLS OCCURRING INSIDE HOOD.
- DO** - USE ONLY GROUNDED ELECTRIC EQUIPMENT.
- DO** - REPORT ANY MALFUNCTION OF THE EXHAUST SYSTEM.
- DO** - ELEVATE CONTAMINATES AND EQUIPMENT ABOVE WORKSURFACE OF HOOD ENABLING AIR FLOW BE NEATH AND AROUND.
- DO** - KEEP MOVEMENTS IN THE HOOD AND IN FRONT OF THE HOOD TO A MINIMUM.
- DO** - CHECK FUME HOOD FACE VELOCITY ON A REGULAR SCHEDULE.
- DO NOT** - USE HOOD UNLESS EXHAUST SYSTEM IS IN OPERATION.
- DO NOT** - CHANGE DAMPER OR BAFFLE SETTINGS AFTER INITIALLY SET.
- DO NOT** - USE FUME HOOD FOR STORAGE OF CORROSIVE OR VOLATILE MATERIALS.
- DO NOT** - BLOCK BAFFLE OR GRILL OPENINGS.
- DO NOT** - GENERATE LARGE QUANTITIES OF INFLAMMABLES WITHIN THE FUME HOOD.
- DO NOT** - PERMIT TEMPERATURES OF SASH GLASS TO EXCEED 160 DEGREES FAHRENHEIT.
- DO NOT** - PLACE UPPER BODY OR HEAD INSIDE THE FRONT PLANE OF THE HOOD OPENING.
- DO NOT** - OPEN OR CLOSE SASH SWIFTLY AS THIS MAY CAUSE ADVERSE AIR FLOW CURRENTS.
- DO NOT** - APPROACH OR LEAVE HOOD FACE SWIFTLY AS THIS MAY CAUSE ADVERSE AIR FLOW CURRENTS.

FUME HOOD OPERATION

Safety considerations require that a schedule of inspections and documentation be set up for every laboratory fume hood.

An inspection record should be maintained. This record may be in the form of a label attached to the fume hood or a log maintained by the laboratory director or safety officer.

Inspection procedures should include instrument verification of fume hood face velocity performance and usage by observations and interview.

Procedures should consist of a physical examination of liner condition and cleanliness, baffle and sash operation and condition, sash cable and guide wheels, and service fixture function.

All results should be recorded and reported to the proper authority for any required action.

NOTE: Special purpose fume hoods such as those used with radioactive materials or perchloric acids require additional inspection procedures to cover special equipment and requirements.

Options, such as airflow monitors or other types of monitors should be inspected annually.

Fume hood air face velocity is an important consideration. 100 feet per minute (FPM) is the standard requirement. Velocities in excess of 150 FPM may reduce fume hood performance and create hazardous condition(s).

The establishment of the proper face velocity for a specific laboratory fume hood should be based on a number of factors. The nature of the fumes emitted from the hood is of obvious importance. Consult your company safety department for recommendations covering the materials you plan on using.

Cross-drafts, created by the room ventilation system or from an open window or corridor, if located adjacent to the hood, can drastically disturb the flow of air entering the fume hood face and even cause a reverse flow of air out of the front of the hood. Room conditions such as these should be avoided. The velocity of the cross drafts should not exceed 20 percent of the fume hood face velocity.

Your Laboratory Safety Plan and Company Procedures should combine to create a safe and healthful work environment.

MAINTENANCE

SASH

Standard fume hoods are provided with a type of movable sash or viewing window. The sash should be cleaned frequently to avoid the possibility of residue building up on the surface. A soft, cloth and mild cleaner should be used for best results.

FUME HOOD

Cleaning of fume hoods should include the removal of the baffle for full cleaning of interior surfaces. Sash guides, cables, pulley wheels and other working parts should be lubricated regularly. Spills should be flushed immediately using neutralizing compounds as required and cleaned thoroughly afterwards. If sashes are grabbing, lubrication of pulleys with a good quality machine oil and application of paraffin to sliding surfaces will help performance substantially. General cleaning can be done with mild detergents and water.

CABINETS

Although designed for wear and tear, the life of cabinets can be greatly extended through observance of proper cleaning and maintenance procedures. Drawers that are overloaded, doors misadjusted, and locks which malfunction can lead to undue stress on equipment, and can permanently affect performance. Metal casework and hardware should be cleaned periodically with good quality cream furniture Polish or an automotive cleaner and finishing wax. Use of rubbing compound often can restore superficial abrasions. Spills should be cleaned up immediately followed by a wash down with detergent and water. Corrosive reagents should be stored in well ventilated casework specifically designed for corrosive storage. HEMCO offers a complete line of acid/corrosive cabinets and flammable/combustible cabinets.

WORKSURFACES

Epoxy Resin - Fine scratches will usually disappear when the top is cleaned with a good quality liquid furniture polish. Mildly abrasive cleaners can be used for stain removal.

SERVICE FIXTURES

Fixtures which have been subjected to chemical fumes over a prolonged period of time may show signs of corrosion. When this occurs thorough cleaning with formulated chrome cleaner followed by an application of paste wax is recommended.

Epoxy-coated fixtures used in chemical areas can be cleaned with detergent and water, dried, and lightly polished with a soft cloth. Do not use abrasive cleaners. High temperatures may alter the color of the plastic coating on fixtures; this condition cannot be cleaned away, but the chemical resistance of the finish is unchanged. A break in the plastic coating of these fixtures should be touched up immediately with matching paint or lacquer to protect the fixture.

BLOWER LOCATION AND SIZE

Where the building design permits, the exhaust blower should be located on the roof of the building to provide a negative pressure in the portion of the duct system located within the building. The exhaust blower should be sized to exhaust the volume of air necessary to attain the selected fume hood(s) design face velocity at the total system static pressure loss. Blower should also be sized to achieve the lowest practical rotational speed thereby minimizing noise/vibration.

BLOWER INSPECTION

It is recommended that both the blower motor and blades be periodically inspected. Belt wear, blade corrosion and exhaust port clogs are examples of blower problems that can develop over long-term use.

THE ROOM MAKE-UP AIR DELIVERY SYSTEM

Make-up air is a ventilation term describing the bringing in of outdoor air to “supply” the building with air removed by the exhaust ventilation system, creating a balance. In general, laboratories require eight – twelve total volume changes per hour. Special applications may require up to 20 air changes per hour. Make-up air is necessary in any lab with an operating fume hood. The air can be provided by either building HVAC ductwork, or by an auxiliary air plenum system. A sufficient quantity of make-up air must be available to allow fume hoods to develop required face velocities. Consideration must be given to the make-up air required for air changes in each specific laboratory involved.

DUCTING

Ducting should be checked periodically for possible leaks.

FACE VELOCITY - CALIBRATION

Fume hood face velocity should be checked at a minimum annually, recommend checking face velocity biannually and the findings recorded and compared with previous readings. Significant changes in face velocity should be reported and investigated. Changes in face velocity may be caused by supply air changes, exhaust blower problems, or loose, broken, corroded, or blocked ducting. Recommended test protocol is at a minimum the face velocity and smoke visualization sections of the ASHRAE 110 – 1995 or current test procedure.